

# Bulldog Grade 2 Interconnect Installation Instructions



The Instructions provide the Information on how to install your lock properly. Read the Instructions carefully before installation.

BEFORE PROCEEDING:

## 1. CHECK THICKNESS OF YOUR DOOR

Be sure that your door thickness is 1-3/8"(35mm)–2"(51mm).

## 2. CHECK BACKSET OF YOUR LOCK

Backset, 2-3/8"(60mm) or 2-3/4"(70mm), is indicated on packaging box, some models are supplied with adjustable latch.

## 3. CHECK BACKSET OF YOUR DOOR

Backset is the distance measured from door edge to center of lock, either 2-3/8"(60mm) or 2-3/4"(70mm).

## 4. MATCH BACKSET OF YOUR LOCK WITH BACKSET OF YOUR DOOR

Make sure your lock has the same backset as your door. For lock supplied with adjustable latch, you may adjust the backset if necessary according to instructions of LATCH BACKSET ADJUSTMENT.

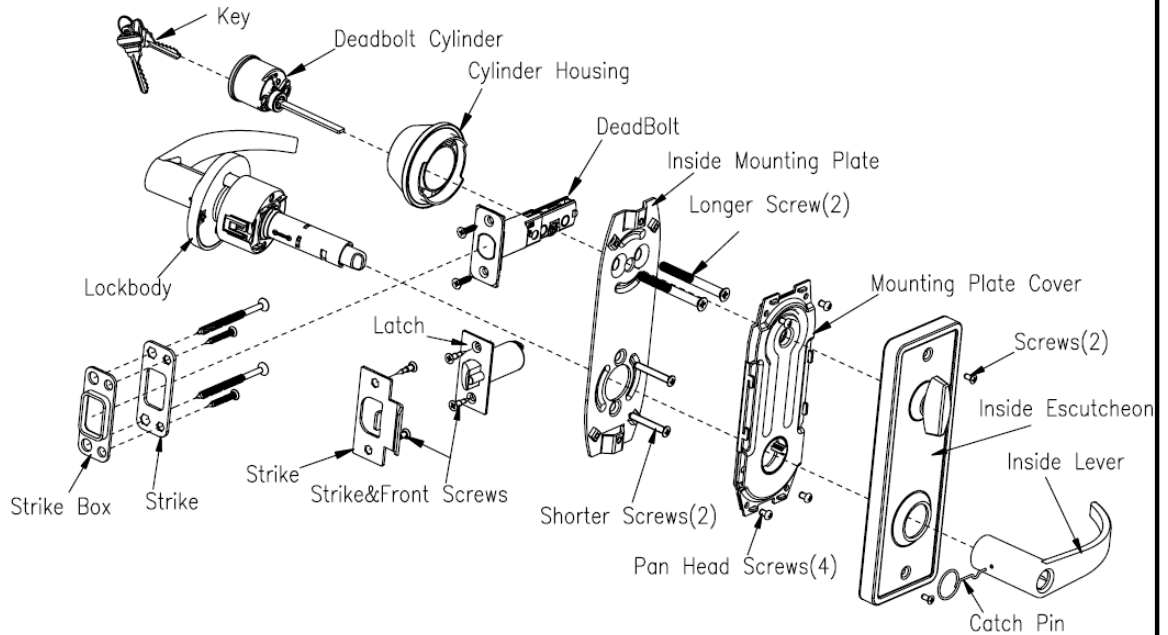

## 1. MARK DOOR

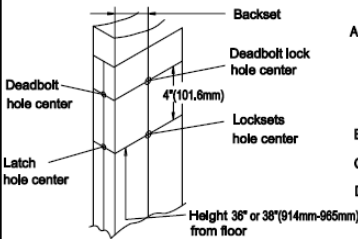

- Start approximately 36" or 38"(914mm-965mm) from floor, select backset, 2-3/8"(60mm) or 2-3/4"(70mm), fold and apply template to the edge of door bevel.
- Mark hole center on door face for deadbolt lock.
- Mark hole center on door face for locksets.
- Mark two hole centers in door edge for latches.

## 4. INSTALL STRIKES

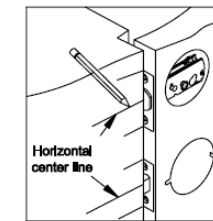

- Close door until latchbolt touches door jamb.
- Mark horizontal center line along latch face.
- Measure one half of door thickness from door stop and mark vertical center line.
- Extend horizontal center line and vertical center line, then mark center points for strikes.

## 2. BORE HOLES

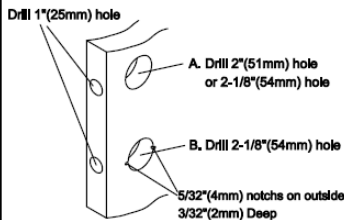

- Drill a 2"(51mm) or 2-1/8"(54mm) hole through door face.
  - Drill a 2-1/8"(54mm) hole through door face.
  - Drill two 1"(25mm) holes in door edge.
- Note: It is recommended to drill holes from both sides of door in A, B to avoid splitting.

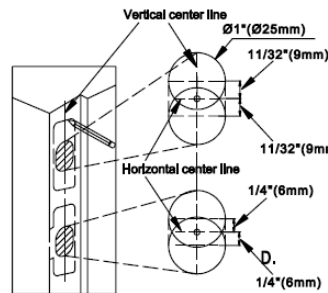

- Upper hole: Bore 1"(25.4mm) overlapping holes 1-1/16" (27mm) deep in door jamb as shown. Clean out hole for bolt clearance. Place strike over strike box and trace for cutout. Chisel 3/16"(4.5mm) deep or until strike flush to edge of door jamb.
- Lower hole: Bore 1"(25.4mm) overlapping holes 3/8" (13mm) deep in door jamb as shown. Clean out hole for bolt clearance. Place strike and trace for cutout. Chisel 5/64"(2.0mm) deep or until strike flush to edge of door jamb.

## 3. INSTALL LATCH AND DEADBOLT

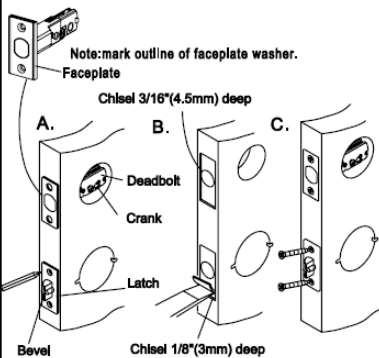

- Insert deadbolt into hole in door edge, keeping latch face parallel to edge of door. Mark outline of latch face and remove latch.
- Chisel 1/8"(3mm) or 3/16"(4.5mm) deep until latch face flush to door edge.
- Insert latch into hole and tighten wood screws.

- Latchbolt bevel must face to closing direction.
- Crank hole must be in down position.

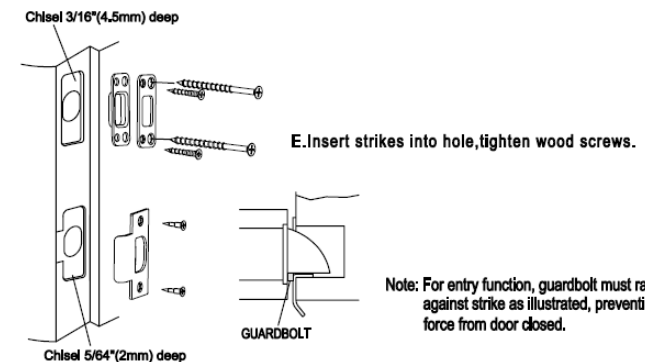

Note: For entry function, guardbolt must ram against strike as illustrated, preventing force from door closed.

# Bulldog Grade 2 Interconnect Installation Instructions

## 5. INSTALL LOCKSET

- A. Remove inside lever from lock, using catch tool.  
 B. Install lock body into door and engage latch as detailed. < per as image below >

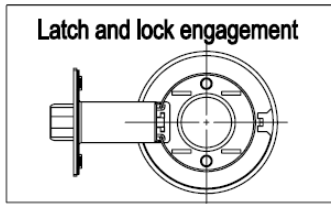

- C. Install inside mounting plate with 2 Shorter Screws.  
 D. Install deadbolt cylinder by slide tailpiece horizontally with 2 Longer Screws.  
 E. Install mounting plate cover align the driver tab with slot within the lockbody, align upper cam silt so that it is horizontal. < per as image below >

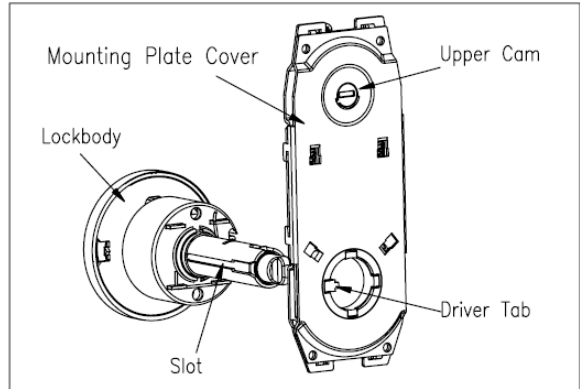

NOTE: Key hole must be downward (shown in fig).

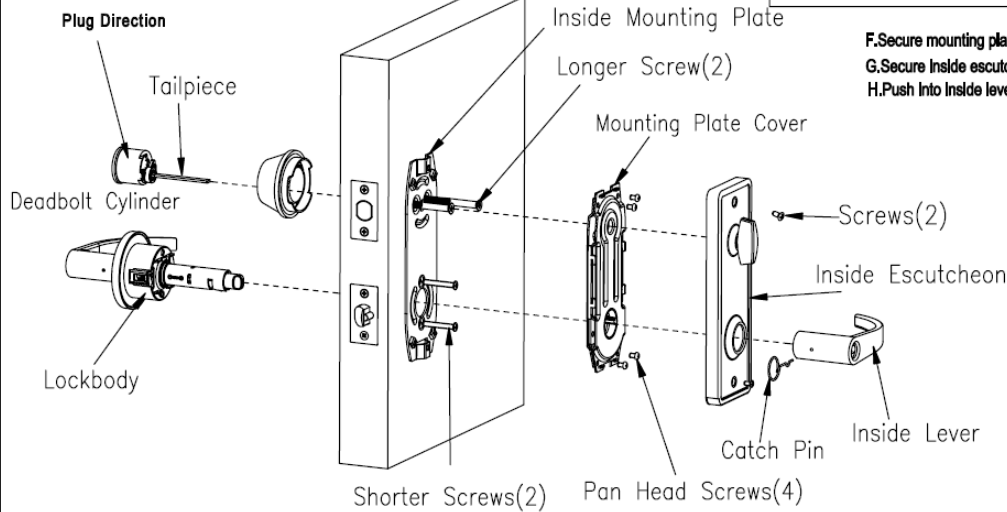
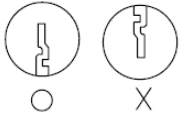

- F. Secure mounting plate cover with 4 pan head screws.  
 G. Secure inside escutcheon with 2 screws.  
 H. Push into inside lever.

## 6. ADJUST TO DOOR THICKNESS

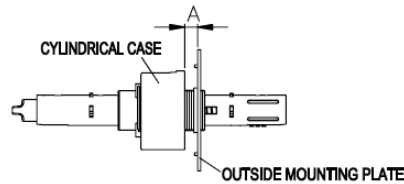
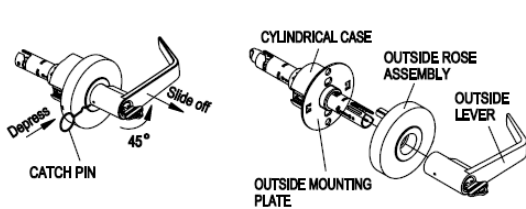

DOOR THICKNESS	DISTANCE "A"
1-3/8" (35mm)	7/64" (2.8mm)
1-9/16" (40mm)	7/32" (5.3mm)
1-3/4" (45mm)	5/16" (7.8mm)
2" (51mm)	27/64" (10.8mm)

- A. Insert key and turn it 45° to the right (or left);  
 B. A lever catch is a hole in the rear of outside lever shank. Depress catch pin onto lever catch to disassemble outside lever and outside rose assembly. (Note: lock must be in open status when disassemble)

- C. To fit different door thickness, rotate outside mounting plate to adjust distance "A" (Distance "A" is distance from outside mounting plate to cylindrical case) as above.

## LATCH BACKSET ADJUSTMENT

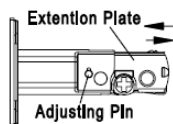

Backset 2-3/8" (60mm)

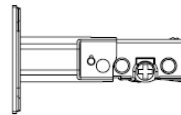

Backset 2-3/8" (70mm)

- a. Move backset from 2-3/8" (60mm) to 2-3/4" (70mm):  
 Pull Adjusting Pin up and move Extention plate all the way to the right and then release it.

- b. Move backset from 2-3/4" (70mm) to 2-3/8" (60mm):  
 Pull Adjusting Pin up and move Extention plate all the way to the left and then release it.

NOTE: 1. Adjusting Pin must return to original position after moving it. 2. Be careful on adjusting backset from 2-3/8" (60mm) to 2-3/4" (70mm).